



GREWIN INDUSTRIAL GROUP CO.,LTD.

TEL/WhatsApp: +86 18622096679

Mail: admin@coilwindingmachinechina.com

Web:www.coilwindingmachinechina.com



WhatsApp



WeChat

NAME:GW-DS09 Double -station stator winding machine (inner winding machine)



2. The overall introduction of the machine and the characteristics of general technology

- 1) Automatic type: Winding action, cross -wire action, 2 stations, single -wire mouth
- 2) Production wire beat: Differential shooting according to the number of winding turns, stacked thickness different sections
- 3) Power: AC 380V \pm 10% 50Hz
- 4) Compressed air: 5-6bar
- 5) The temperature is -10 ~ 40 ° C, and the humidity is 40 to 80%.

GREWIN INDUSTRIAL GROUP CO.,LTD.

Add: The fourth floor A-A3 zone aviation business area,Dongli Distr,Tianjin,China.



GREWIN INDUSTRIAL GROUP CO.,LTD.

TEL/WhatsApp: +86 18622096679

Mail: admin@coilwindingmachinechina.com

Web:www.coilwindingmachinechina.com



WhatsApp



WeChat

- 6) The layout of the entire line is planned as a straight wire, occupying 1000*1600*2100mm
- 7) The winding wires are beautiful, arranged neatly, and the lacquer bag is not damaged (according to the requirements of the national standard)
- 8) Model change time: The device should have the function of fast mold changes.
- 9) Program call: The device should have the function of program storage, that is, the corresponding program corresponding to different types of products, directly call during production.
- 10) Power management

First -level permissions: The operator is used, you can switch the device normally, call the set authority to produce products and other permissions.

Two -level permissions: The use of debugging personnel can modify the setting parameters and other permissions.

Three -level permissions: use of equipment maintenance personnel, perform equipment maintenance and diagnosis, password modification and other permissions.

3. The shape and appearance requirements of the winding machine (for reference only, based on actual supply)

3.1 device shape (layout)

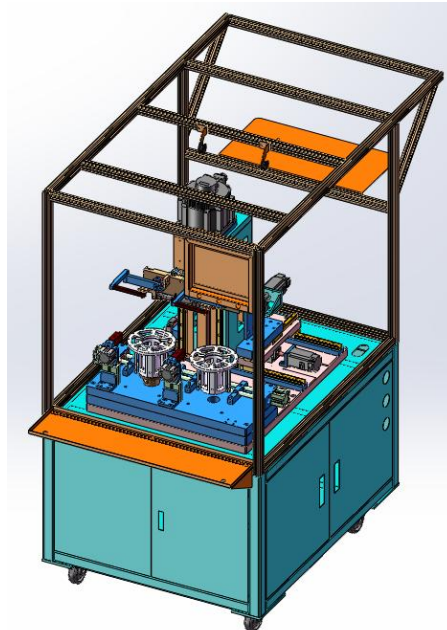

GREWIN INDUSTRIAL GROUP CO.,LTD.

Add: The fourth floor A-A3 zone aviation business area,Dongli Distr,Tianjin,China.



GREWIN INDUSTRIAL GROUP CO.,LTD.

TEL/WhatsApp: +86 18622096679

Mail: admin@coilwindingmachinechina.com

Web:www.coilwindingmachinechina.com



WhatsApp



WeChat

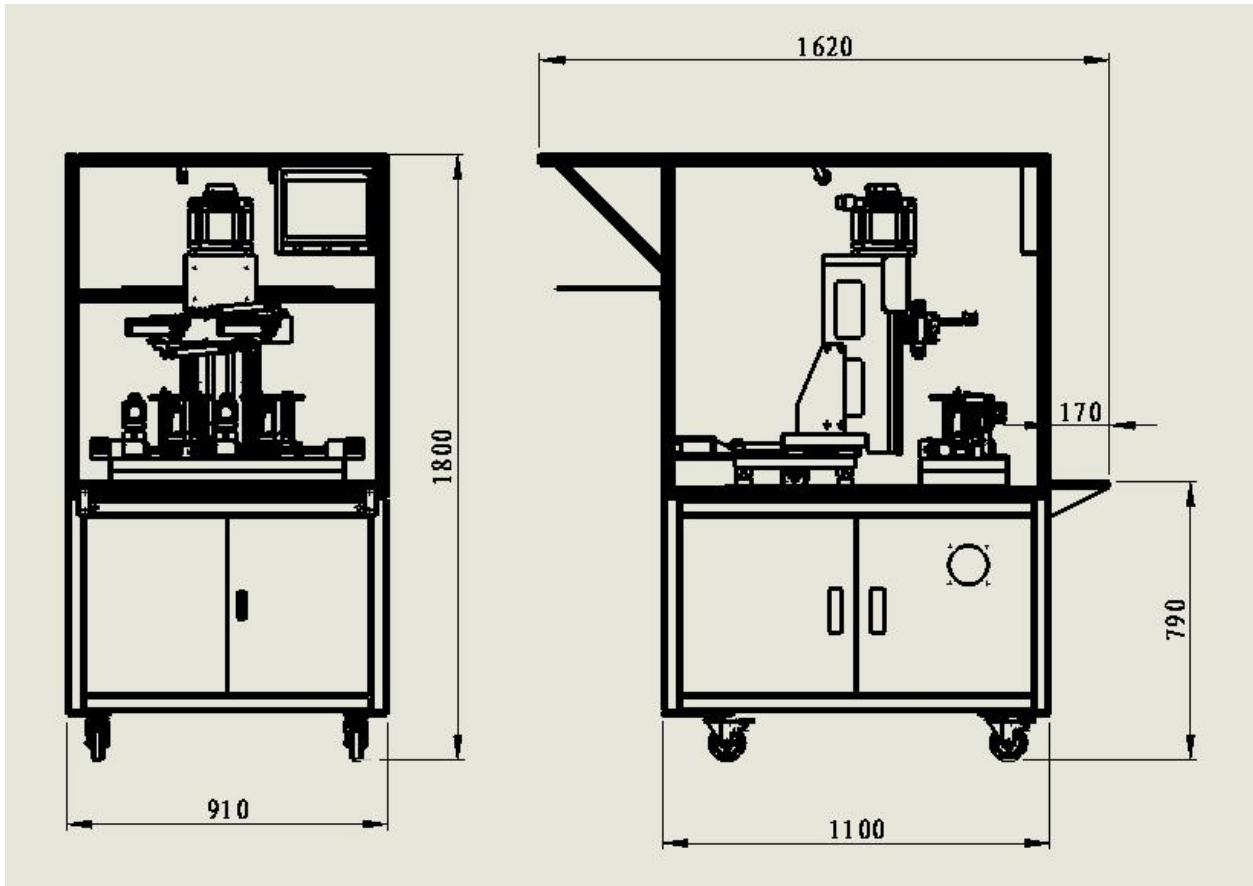

3.2 Surface Treatment

The surface around the equipment body is sprayed white, and the profile frame plexiglass is transparent blue.

3.3 Moving

The equipment shall be equipped with fixed feet and movable feet.

3.4 Electrical Access

Equipment should be equipped with electrical fast interface

4. Other key parameters

Parameter:	
Winding method:	internal winding machine
Maximum outer diameter that can be wound:	≤170mm
Applicable rotor stack thickness:	≤90mm
Wire diameter:	0.2mm-1.4mm
Safety protection:	two-hand start + raster sensor
Power Supply:	three-phase 380V (±10%)
Air Source:	0.4-0.6 Mpa
Axis of rotation (A1/A2 axis)	
Number of axis:	2

GREWIN INDUSTRIAL GROUP CO.,LTD.

Add: The fourth floor A-A3 zone aviation business area,Dongli Distr,Tianjin,China.



GREWIN INDUSTRIAL GROUP CO.,LTD.

TEL/WhatsApp: +86 18622096679

Mail: admin@coilwindingmachinechina.com

Web:www.coilwindingmachinechina.com



WhatsApp



WeChat

Shaft spacing:	260mm
Rotation shaft motor power:	servo 4.5KW*2, Taiwan Yitu absolute position servo
Positioning accuracy of transposition axis:	≤±0.5°
Rotation axis mode:	servo motor
Z-winding:	
Z-direction motor:	servo ≥5KW, Taiwan Yitu absolute position servo
Three-dimensional mobile device:	
Drive motor:	X 400W Taiwan Yitu absolute position servo Y 400W Taiwan Yitu absolute position servo
3D travel:	X≤180mm; Y≤120mm; Z≤200mm
Moving speed:	≥100mm/s
Scissors device:	
Lead length:	according to drawing requirements
Scissor mode:	pneumatic
Scissors can cut wirediameter range:	0.2~1.5mm

5.Basic equipment configuration

Key component name		Brand
Machine	Solenoid valve:	AirTAC
	Cylinder:	Airtac
	Linear guide rail:	Taiwan Shang Yin
	Ball screw:	German Rexroth
	Pneumatic scissors:	domestic
	Main shaft bearing:	NSK
Electric:	Servo motor:	Taiwan Edu absolute position servo
	Control system:	Taiwan Yitu A6/CNC system
	Power switch:	Japan Mitsubishi
	Switching power supply:	Taiwan Mingwei
	Button:	Schneider
	Photoelectric sensor:	Omron
	Touch screen:	Taiwan Edu
Raster:	Ottonicus	

PACKAGING:

Packaging Material: Carton/Wooden case with foam inside.

1.General package(Paper carton or plastic bag): For small euipped parts for Multi Spindle Coil Winding Machine , Package it with form and pack paper to guarantee unbroken during the transport.

GREWIN INDUSTRIAL GROUP CO.,LTD.

Add: The fourth floor A-A3 zone aviation business area,Dongli Distr,Tianjin,China.



GREWIN INDUSTRIAL GROUP CO.,LTD.

TEL/WhatsApp: +86 18622096679

Mail: admin@coilwindingmachinechina.com

Web:www.coilwindingmachinechina.com



WhatsApp



WeChat

2. Wooden case package: For larger scale Multi Spindle Coil Winding Machine ,we have special skilled carpenter, who would make the proper wooden case with exact thickness,density,length. The up arrow ↑marked on the outer wooden case. Buffer material would be put in the wooden case to prevent crack and shock.



FACTORY:

We-GREWIN INDUSTRIAL GROUP is expert in winding machines lines for 28Years. Our Grewin have ISO9001:2015,CE approvals,Machines'Patents,"high-tech enterprises"by the government.

GREWIN INDUSTRIAL GROUP CO.,LTD.

Add: The fourth floor A-A3 zone aviation business area,Dongli Distr,Tianjin,China.



GREWIN INDUSTRIAL GROUP CO.,LTD.

TEL/WhatsApp: +86 18622096679

Mail: admin@coilwindingmachinechina.com

Web:www.coilwindingmachinechina.com



WhatsApp



WeChat



GREWIN INDUSTRIAL GROUP CO.,LTD.

Add: The fourth floor A-A3 zone aviation business area,Dongli Distr,Tianjin,China.